



Product Specification

5050SMD RGB LED Strip Light (DLST5050-72W-RGB)



1. Features:

- Decent decorative 5050SMD RGB LED strip light
- 5050SMD RGB, 60pcs/m, 14.4w/m, 300LEDs in 5m
- Compatible with both 12V and 24V input
- Quality flexible 10mm width PCB, suitable for various installation
- 5m per roll, every 3pcs LEDs as one set can be cuttable
- Available in waterproof(IP65 & IP67) and non-waterproof (IP20)

2. Product Characteristics:

Product Type	5050SMD RGB LED Strip Light
Model	DLST5050-72W-RGB
LED type	5050SMD RGB
Input Voltage	DC12V/24V
Rated Power	72W(14.4w/m)
Length	5m
CCT	RGB
CRI	>80Ra
Beam angle	120°
PCB color	white
PCB width	10mm
IP	IP20/ IP65/ IP67
Warranty	3 years

2. Installation wiring:

1) For single RGB LED strip light

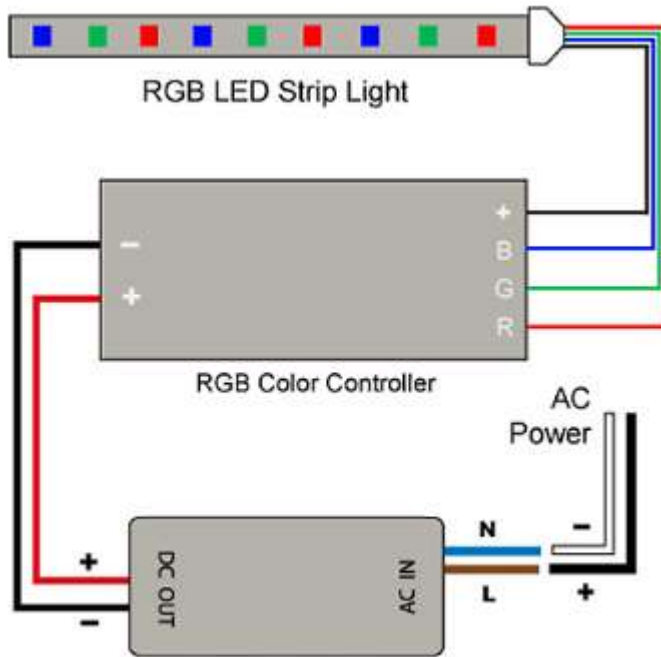

2) For multiple RGB LED strip light

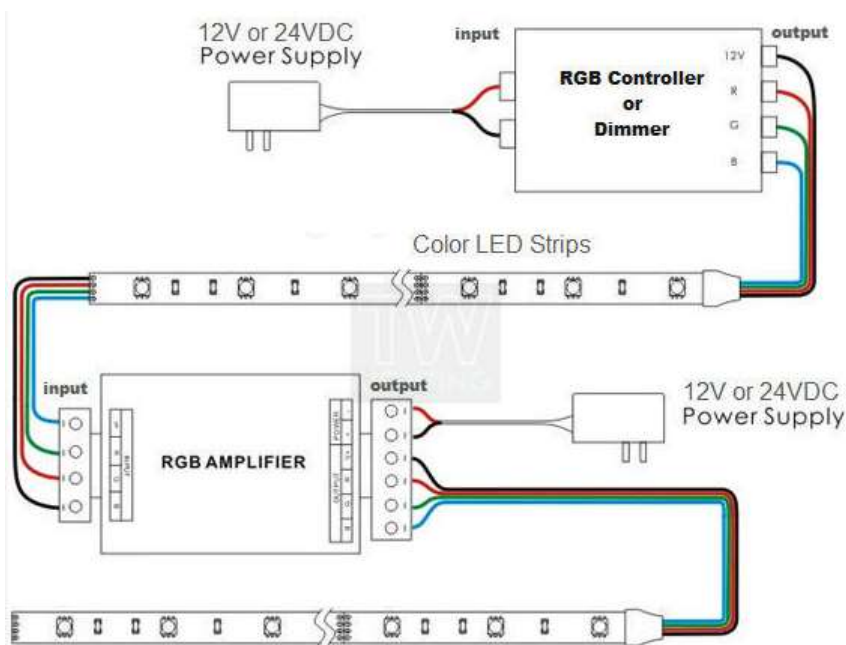

3. Packing: 100rolls/carton

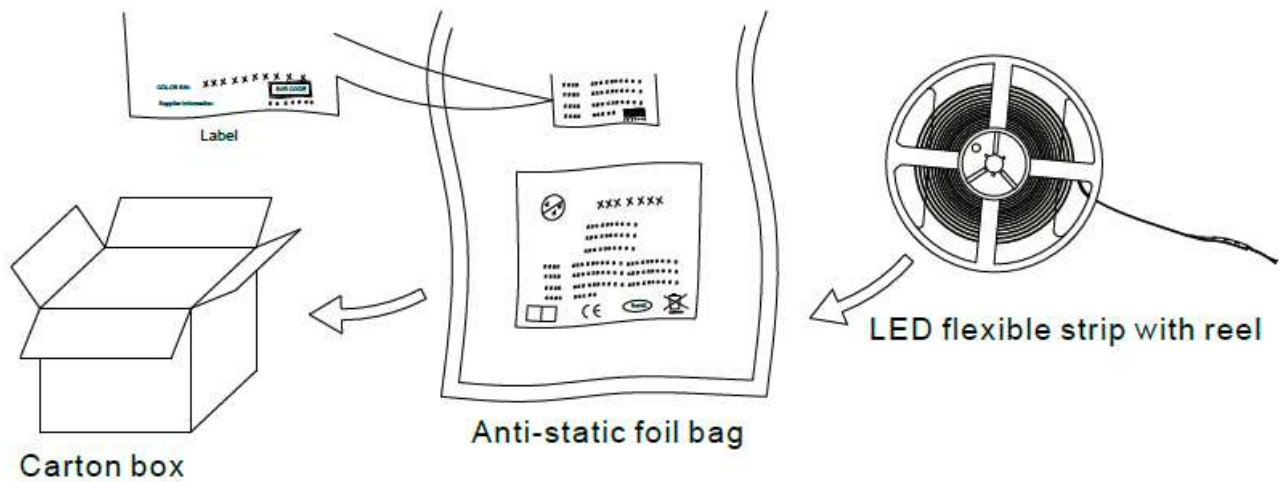

3. Areas of application:

- ※ Hotel
- ※ bar
- ※ corridor
- ※ kitchen
- ※ signage

4. Quality Warranty:

- ※ Warranty period for 3 years
- ※ Quality guarantee is based on storing, installing, operating and maintaining correctly in the normal operation condition.
- ※ It is not included in our maintaining range when installing inappropriately, breaking the operating rules, and leading to the products damaging.
- ※ Our company will maintain the right to either repair, parts replacing, or products exchange during the quality warranty period.

5. Safety Note:

- ※ Please do not touch and twist the lamp when power is on.
- ※ Please arrange installation by qualified professional technician only.
- ※ 5M in a serial connection maximum.
- ※ The power wire between power supplier and LED strips should be less than 2 meters to keep the same brightness on all parts.